



GPS Receiver A1035-H

**A Description of Maestro's
GPS Receiver / Smart Antenna Module A1035-H**

User's Manual

Version 1.4

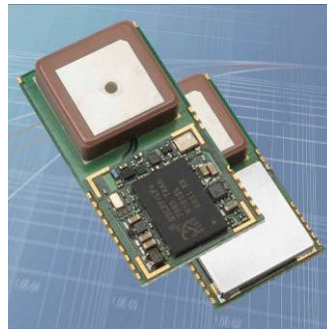

Revision History

Rev.	Date	Description
1.0	01-26-09	Release
1.1	02-09-11	1. Correction of additional solder pad information 2. Added nRST information link in signal table; comments on boot select added 3. Added chapter on evaluation kit 4. Corrected soldering profile; extended temperature range specification with slightly decreased performance below -30°C; corrected (decreased) current draw figures; added chapter on antenna supply switch; added hint on “Ephemeris Push”; corrected reel and box quantities 5. New label description (introduced cw50/09); extended minimum configuration; application note on Hibernate Mode extended (use of ON_OFF pin or Shutdown Command)
1.2	05-05-11	1. Modify packaging describe
1.3	06-03-11	1. Correction of Mechanical Characteristics
1.4	03-01-12	1. Add Firmware Updates information
	mm-dd-yy	

	Name	Date	Signature
Written by	Happy wen	03-01-12	H W
Checked by	Sam Law, Wallace Lee	03-01-12	S L, W L
Approval by	Frank Tang, Calvin Yau	03-01-12	F T, C Y

Disclaimer

THIS DOCUMENT CONTAINS PROPRIETARY INFORMATION OF MAESTRO WIRELESS SOLUTIONS LIMITED. IT MAY NOT BE COPIED OR TRANSMITTED BY ANY MEANS, PASSED TO OTHERS, OR STORED IN ANY RETRIEVAL SYSTEM OR MEDIA, WITHOUT PRIOR CONSENT OF MAESTRO OR ITS AUTHORIZED AGENTS.

THE INFORMATION IN THIS DOCUMENT IS, TO THE BEST OF OUR KNOWLEDGE, ENTIRELY CORRECT. HOWEVER, MAESTRO CAN NEITHER ACCEPT LIABILITY FOR ANY INACCURACIES, OR THE CONSEQUENCES THEREOF, NOR FOR ANY LIABILITY ARISING FROM THE USE OR APPLICATION OF ANY CIRCUIT, PRODUCT, OR EXAMPLE SHOWN IN THE DOCUMENT.

THE PRODUCT (HARD- AND SOFTWARE) DESCRIBED IN THIS DOCUMENTATION IS NOT AUTHORIZED FOR USE IN LIFE SUPPORT DEVICES OR SYSTEMS WITHOUT THE EXPRESS WRITTEN APPROVAL OF MAESTRO.

THIS DOCUMENT MAY PROVIDE LINKS TO OTHER WORLD WIDE WEB SITES OR RESOURCES. BECAUSE MAESTRO HAS NO CONTROL OVER SUCH SITES AND RESOURCES, MAESTRO SHALL NOT BE RESPONSIBLE FOR THE AVAILABILITY OF SUCH EXTERNAL SITES OR RESOURCES, AND DOES NOT ENDORSE AND IS NOT RESPONSIBLE OR LIABLE FOR ANY CONTENT, ADVERTISING, PRODUCTS, OR OTHER MATERIALS ON OR AVAILABLE FROM SUCH SITES OR RESOURCES. MAESTRO SHALL NOT BE RESPONSIBLE OR LIABLE, DIRECTLY OR INDIRECTLY, FOR ANY DAMAGE OR LOSS CAUSED OR ALLEGED TO BE CAUSED BY OR IN CONNECTION WITH USE OF OR RELIANCE ON ANY SUCH CONTENT, GOODS OR SERVICES AVAILABLE ON OR THROUGH ANY SUCH SITE OR RESOURCE.

MAESTRO RESERVES THE RIGHT TO CHANGE, MODIFY, OR IMPROVE THIS DOCUMENT OR THE PRODUCT DESCRIBED HEREIN, AS SEEN FIT BY MAESTRO WITHOUT FURTHER NOTICE.

Table of Contents

1 Introduction	6
1.1 Label	6
1.2 Characteristics	7
1.2.1 GPS Characteristics	7
1.2.2 Mechanical Characteristics.....	7
1.3 Handling Precautions	7
2 Ordering Information	8
2.1 GPS Receiver A1035-H	8
2.2 Packing	8
2.3 Additional Equipment	11
3 Quick Start	12
3.1 Minimum Configuration	12
3.2 Antenna.....	15
3.3 Serial Port Settings	15
3.4 Improved TTFB	15
3.5 Firmware Updates(Flash-based module only)	15
4 Mechanical Outline	16
4.1 Details Component Side A1035-H	16
4.2 Details Solder Side A1035-H	17
5 Pin-out Information	18
5.1 Layout A1035-H	18
5.2 Description A1035-H Signals	19
5.3 General Comments	20
6 Electrical Characteristics	21
6.1 Operating Conditions	21
6.2 Absolute Maximum Ratings	21
6.3 DC Electrical Characteristics.....	22
7 Mounting	23
7.1 Proposed Footprint for Soldering	23
7.2 Recommended Profile for Reflow Soldering	23
8 Use of External Antenna	25
8.1 Connection of RF Signal	25
8.2 External Antenna.....	26
8.2.1 Recommended Parameters.....	26
8.2.2 Switching External Antenna Supply.....	27
8.2.3 Hints	27
9 Quality and Reliability	28
9.1 Environmental Conditions	28
9.2 Product Qualification	28

9.3 Production Test.....	28
10 Application and Hints	29
10.1 Minimum Configuration	29
10.2 External Antenna Status Adaptation	29
10.2.1 External Antenna Sensor.....	29
10.2.2 External Antenna Sensor with Current Limiter	30
10.3 VANT Pin (antenna voltage input pin).....	31
10.4 1PPS Pin (1 pulse per second pin)	31
10.5 Reset Signal.....	32
10.5.1 Internal Reset Circuit	32
10.5.2 External Reset Circuit.....	32
10.6 Battery Back-up.....	33
10.7 Push-to-Fix Mode.....	34
10.8 Hibernate Mode.....	34
10.8.1 Entering Hibernate Mode with ON_OFF Pin	34
10.8.2 Entering Hibernate Mode with Shutdown Command.....	34
11 Evaluation Kit EVA1035-H	35
12 Related Information	36
12.1 Contact.....	36
12.2 Related Documents.....	36
12.3 Related Tools	36
13 List of Figures	37
14 List of Tables	38

1 Introduction

Maestro’s GPS receiver module / smart antenna A1035-H is a highly integrated GPS antenna receiver module based on the technology of the GPS receiver module A1084 and a ceramic GPS patch antenna. Like on the A1084-A an RF switch is integrated on the module allowing changing of RF input from the on-module antenna to an external antenna. The module is capable of receiving signals from up to 20 GPS satellites and transferring them into position and timing information that can be read over a serial port. Small size and high-end GPS functionality are combined at low power consumption:

- Operable at 3.3V / 24mA (typ.) @ 1fix per second
- UART interface at CMOS level
- Small form factor of 30.48 x 16.51 mm² (1.2” x 0.65”)
- Supported temperature range: -40°C to +85°C
- Single-sided SMT component, for reflow soldering
- RoHS compliant, lead-free
- Tape & reel packaging
- Excellent antenna support
 - On-module patch antenna
 - Antenna input for direct connection of external active antenna
 - RF switch to select between antennas

The receiver / smart antenna module is available as an off-the-shelf component, 100% tested and shipped in tape-and-reel.

1.1 Label

The A1035-H label (size: 9.5 x 9.5 mm²) contains the following information:



Figure 1: A1035-H label

The label is placed on the shield of the module. The data matrix code holds the product type, software version, software release, hardware release, factory code, year & week of assembly and a 6-digit serial number.

1.2 Characteristics

The module is characterized by the following parameters.

1.2.1 GPS Characteristics

Channels		20, parallel tracking
Correlators		200,000 plus
Frequency		L1 (= 1,575 MHz)
Tracking Sensitivity		
External active antenna		-159 dBm
On-module antenna		-157 dBm
Horizontal Position Accuracy	Stand alone	< 2.5 m CEP (SA off)
Position Accuracy	Stand alone	< 10 m CEP (SA off)
Time To First Fix – TTFF (theoretical minimum values; values in real world may differ)	Obscuration recovery ⁽¹⁾	0.1 s
	Hot start ⁽²⁾	< 1 s
	Warm ⁽³⁾	< 32 s
	Cold ⁽⁴⁾	< 35 s

Table 1: A1035-H GPS characteristics

- (1) The calibrated clock of the receiver has not stopped, thus it knows precise time (to the μ s level).
- (2) The receiver has estimates of time/date/position and valid almanac and ephemeris data.
- (3) The receiver has estimates of time/date/position and recent almanac.
- (4) The receiver has no estimate of time/date/position, and no recent almanac.

Note: Performance (sensitivity and TTFF) might slightly decrease below -30°C .

1.2.2 Mechanical Characteristics

A1035-H Mechanical dimensions	Length	30.48 \pm 0.20 mm, 1.2 \pm 0.008"
	Width	16.51 \pm 0.20 mm, 0.65 \pm 0.008"
	Height	5.10 mm, 0.201"(Max)
A1035-H Weight		4.0 g, 0.14 oz

Table 2: A1035-H dimensions and weight

1.3 Handling Precautions

The GPS receiver module A1035-H is sensitive to electrostatic discharge (ESD). Please handle with appropriate care.

2 Ordering Information

2.1 GPS Receiver A1035-H

The order number is built as follows:

- **A1035-Hxxx**

A1035-H for the A1035-H module. The “xxx” reflects the current firmware version. If no firmware version is noted in an order, the latest version will be provided.

2.2 Packing

The A1035-H GPS modules come in a tape and reel package suitable for pick and place machines.

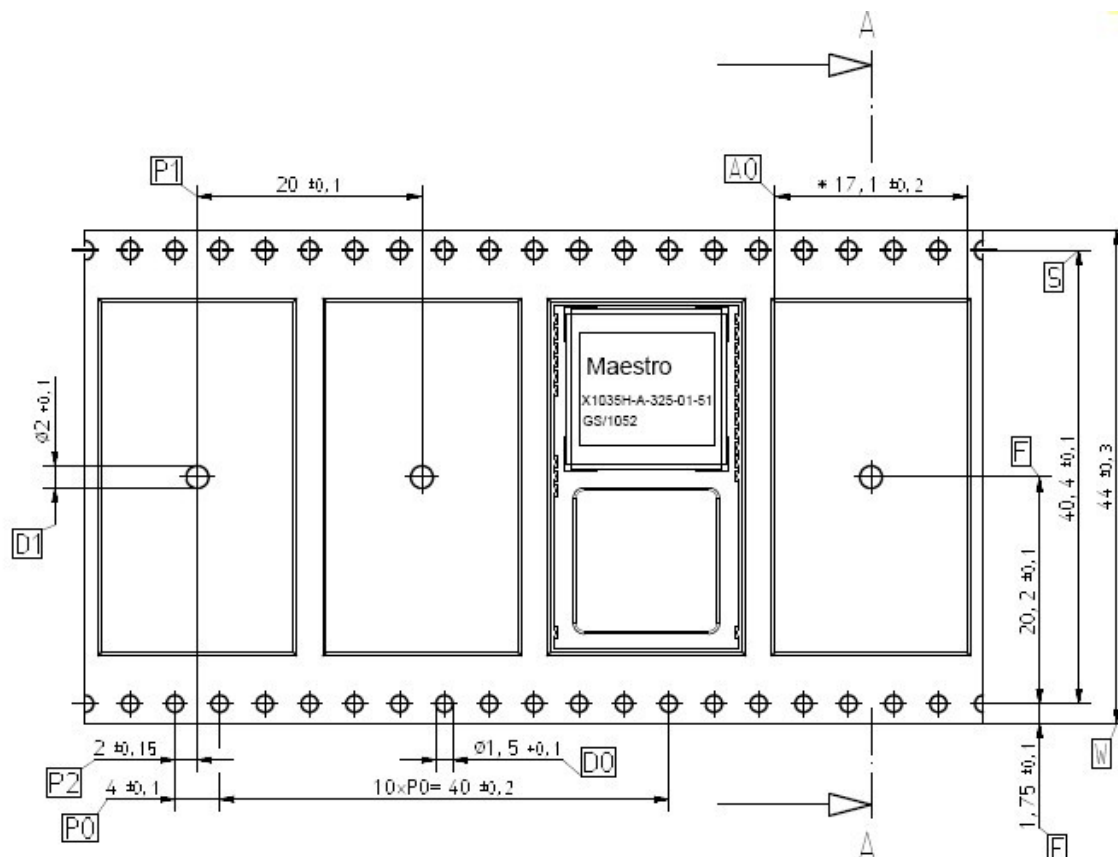

Figure 2: A1035-H tape specifications (1)

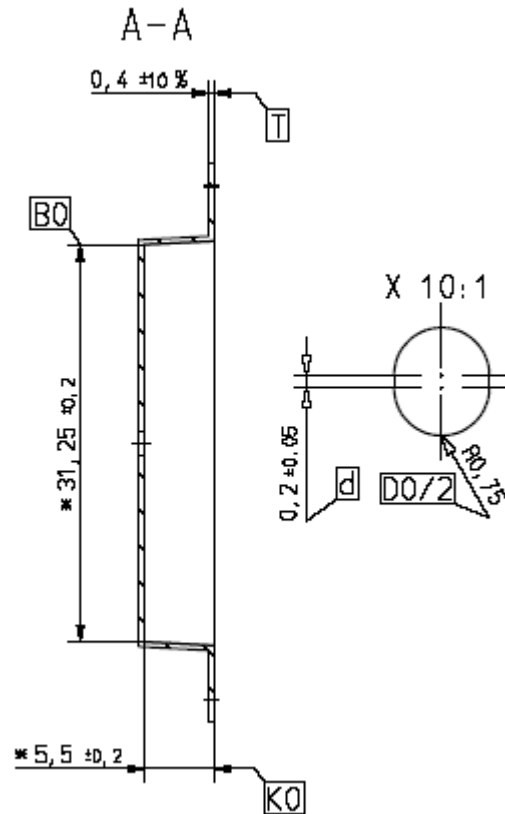

Figure 3: A1035-H tape specifications (2)

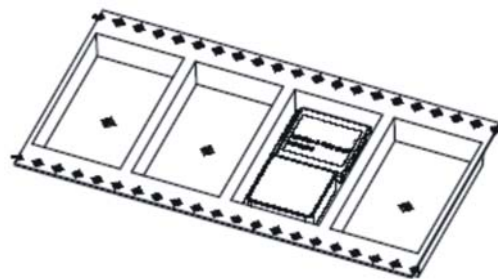

Figure 4: A1035-H tape specifications (3)

One complete reel holds 700 A1035-H modules.

There are 2 kinds of packaging for shipment:

A: One box holds 1 reel

Reel diameter: 38 cm

Outer Box dimensions: 38.8 (W) x 38.8 (L) x 5.7 (H) cm

Gross weight: 5.06 Kg

Net weight: 4.13 Kg

- B: One box holds 2 reels
- Reel diameter: 38 cm
- Outer box dimensions: 38 (W) x 38 (L) x 12.3 (H) cm
- Gross weight: 10.03 Kg
- Net weight: 8.26 Kg

2.3 Additional Equipment

EVA1035-H	Evaluation Kit (including one module A1035-H)
-----------	---

Table 3: Additional equipment

A detailed description of the EVA1035-H Evaluation Kit can be found in the appropriate manual.

3 Quick Start

In order to allow an easy and quick start with the A1035-H module, this chapter provides a short overview on the important steps to be taken to receive NMEA messages with position information on a serial port.

3.1 Minimum Configuration

The following pictures show two versions of recommended minimum configurations for NMEA output and commands sent and received via an RS232 interface based on the GPS antenna module A1035-H using the on-module antenna. While the first version foresees that Vcc is applied continuously, the second version assumes a separate back-up battery. In order to go to Hibernate Mode (low power mode) the two configurations use different approaches. The first version requires toggling of the ON_OFF pin and continued supply of Vcc. With the second version a shutdown command is required; then after a further delay Vcc can be switched off completely. In both cases the current drawn will drop drastically. See also chapter “10.8 Hibernate Mode”.

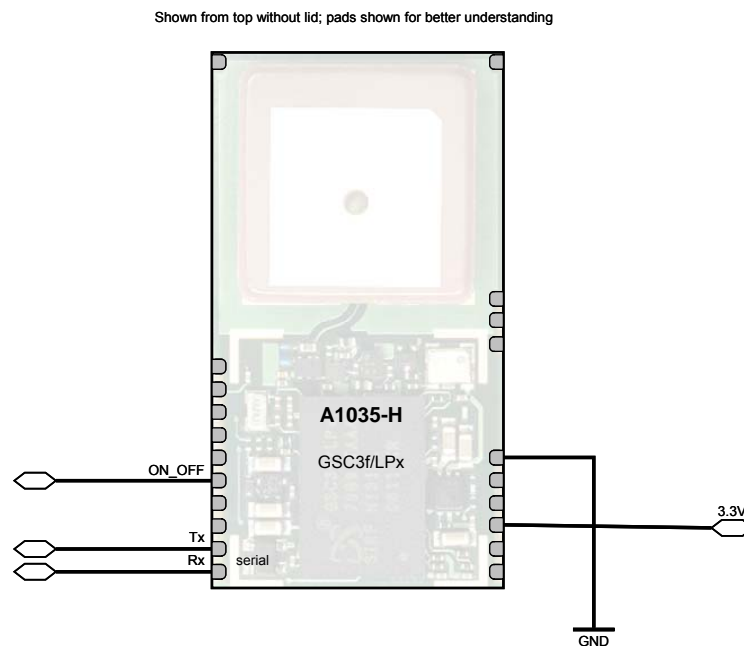

Figure 5: Minimum configuration A1035-H with continued Vcc supply

Remarks:

- Use separate ground plane for antenna ground.
- External antenna input impedance is 50 Ω. Match as close as possible.
- Maximum allowed external antenna current is 50 mA. Consider a current limiter.
- Supply Vcc continuously, use toggling of ON_OFF to switch between normal operation and hibernate mode

Shown from top without lid; pads shown for better understanding

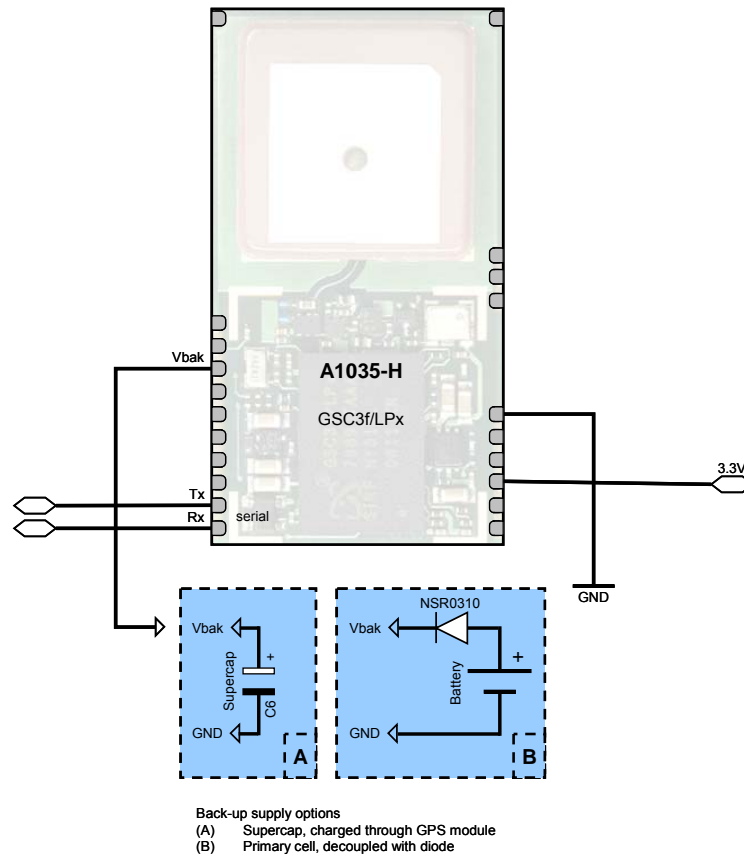

Figure 6: Minimum configuration A1035-H with Vbak

Remarks:

- Use separate ground plane for antenna ground.
- External antenna input impedance is 50 Ω . Match as close as possible.
- Maximum allowed external antenna current is 50 mA. Consider a current limiter.
- A battery back-up circuit for the RTC (Real Time Clock) should be considered (see chapter: "10.6 Battery Back-up")
- Send shutdown command along with a further delay (2s) before switching Vcc off

For completeness the following pictures show the use of an RS232 level shifter.

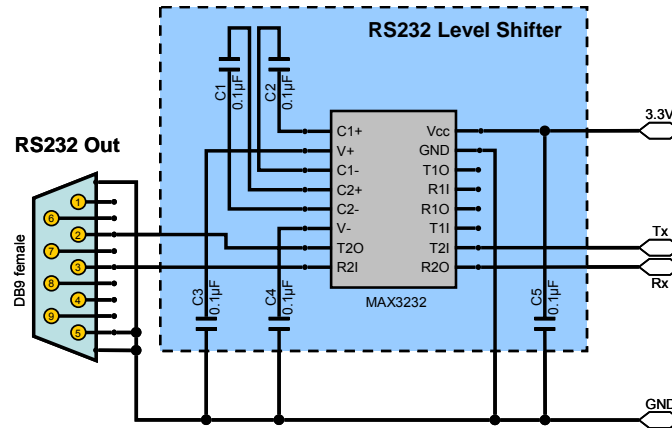

Figure 7: RS232 level shifter for minimum configurations

Remarks:

- Place C1 to C5 (here: $0.1\mu\text{F}$) close to MAX3232. For capacity values see datasheet of actual component used.
- Use 3.3V level shifter (MAX3232 or equivalent).

3.2 Antenna

Although the A1035-H offers an on-module antenna, an additional external active antenna can be used. Switching between both antennas is done via pin 12 (see also “5.2 Description A1035-H Signals”). It is recommended to use an active GPS antenna with supply voltage of 3 to 5 VDC and a current draw of 50 mA maximum. The quality of the GPS antenna chosen is of paramount importance to the overall sensitivity of the GPS system. An active antenna should have a gain ≥ 20 dB and a noise figure ≤ 1.5 dB, which applies to more than 95% of the active antennas available in the market.

3.3 Serial Port Settings

The default configuration within the custom-specific GPS firmware is:

- Serial 0 (NMEA) 4800 baud, 8 data bits, no parity, 1 stop bit, no flow control

3.4 Improved TTFF

In order to improve the TTFF (Time To First Fix), it is recommended to support the RTC and SRAM with a back-up power when no system power is available.

Furthermore, starting with FW revision 3.5.0 “Ephemeris Push” is supported. Please see according application note!

3.5 Firmware Updates(Flash-based module only)

Firmware upgrade function is only valid for Flash-based module. If later firmware changes are considered in a design it is necessary to connect the BOOTSEL pin of the A1035-H. BOOTSEL pin is used to control the mode of operation mentioned on table below:

BOOTSEL	Operating mode
Leave open	Normal operation
Pull up to 3.3V	Boot loader active for firmware upgrade

Table 4: BOOTSEL Operating mode

A specific tool (SiRFFlash) is required for firmware upgrade upon request to Maestro. Recommended circuitry on application board was indicated below.

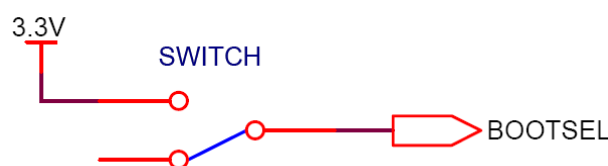
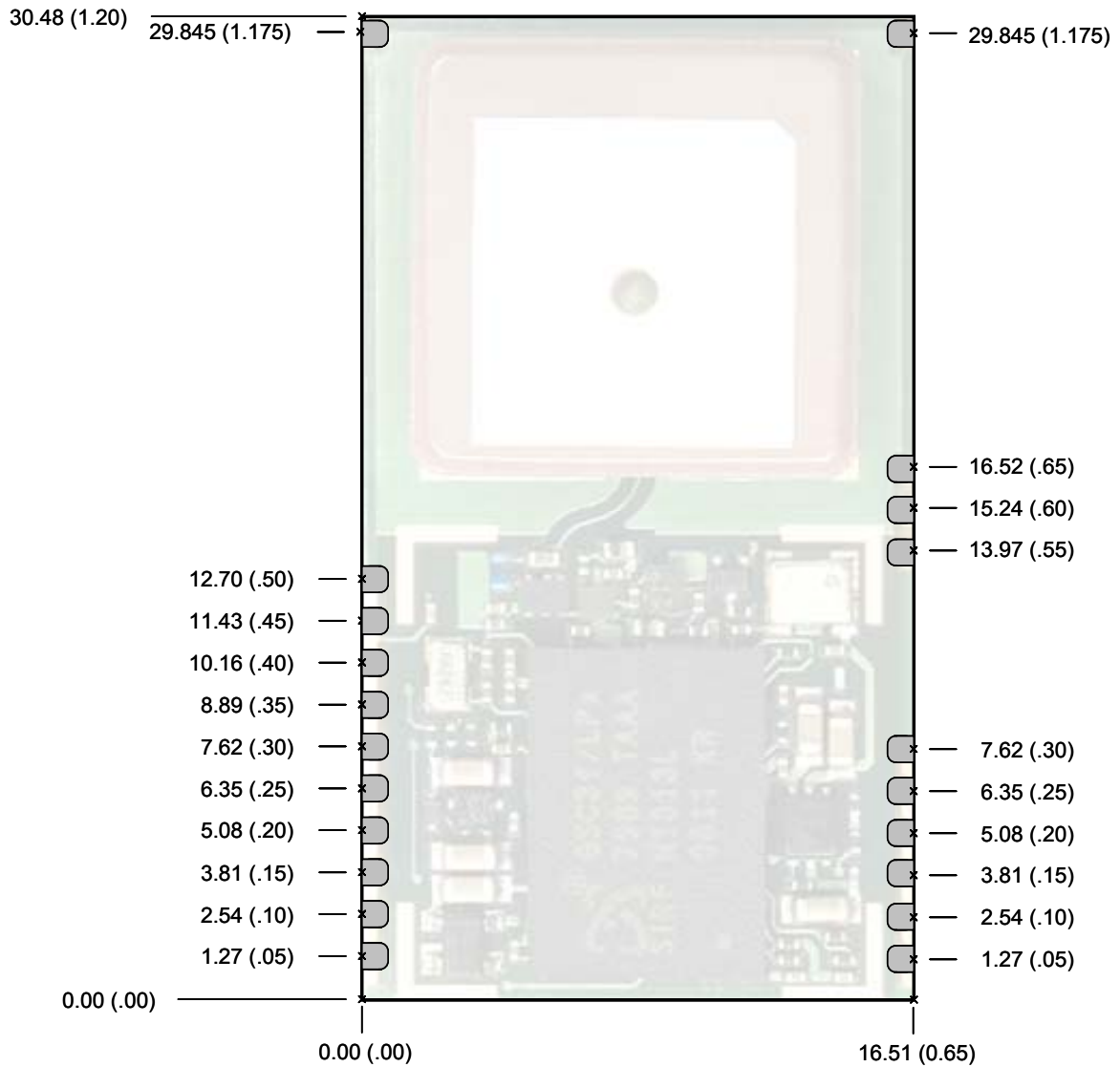

Figure 8: BOOTSEL application

4 Mechanical Outline

4.1 Details Component Side A1035-H



All dimensions in [mm] / [(inches)]

Figure 9: Mechanical outline component side A1035-H

4.2 Details Solder Side A1035-H

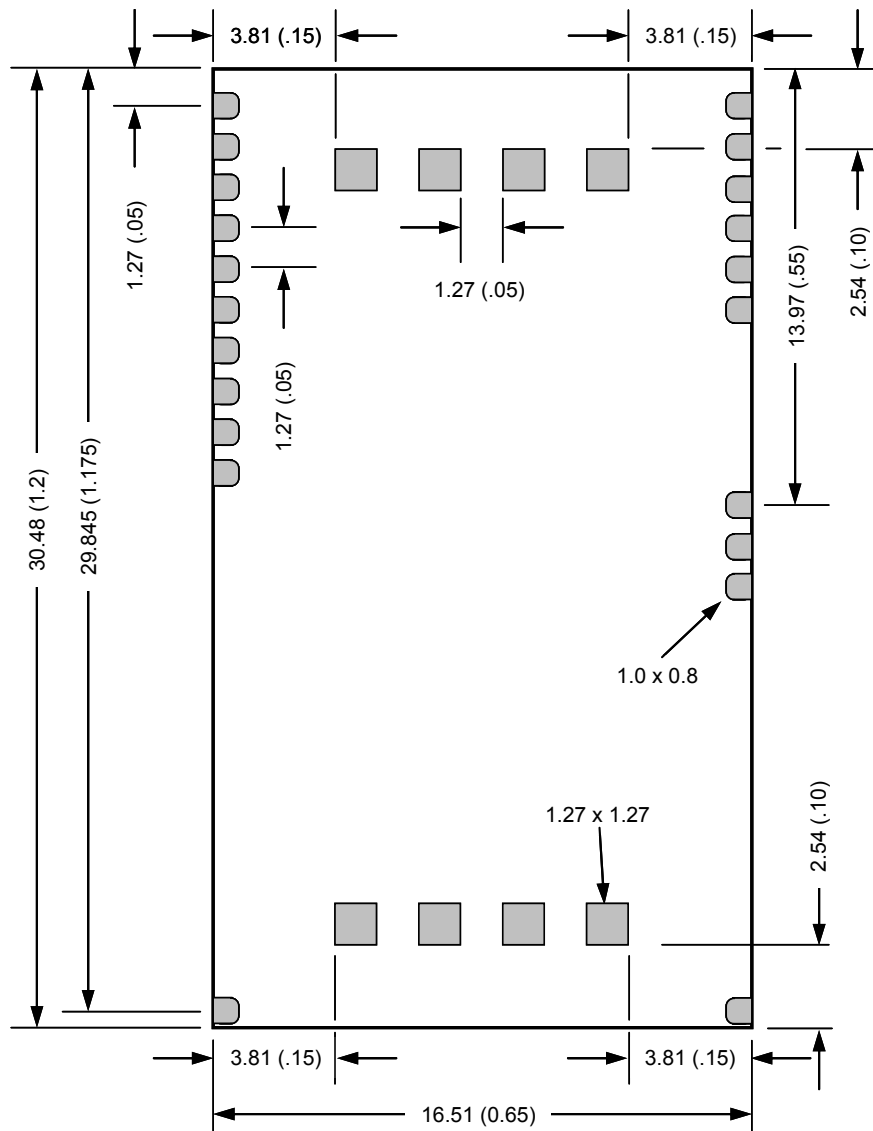

Solder pad size (outer pads): 1.0 x 0.8
 Solder pad size (inner pads): 1.27 x 1.27
 All dimensions in [mm] / [(inches)]

Figure 10: Mechanical outline solder side A1035-H

5 Pin-out Information

5.1 Layout A1035-H

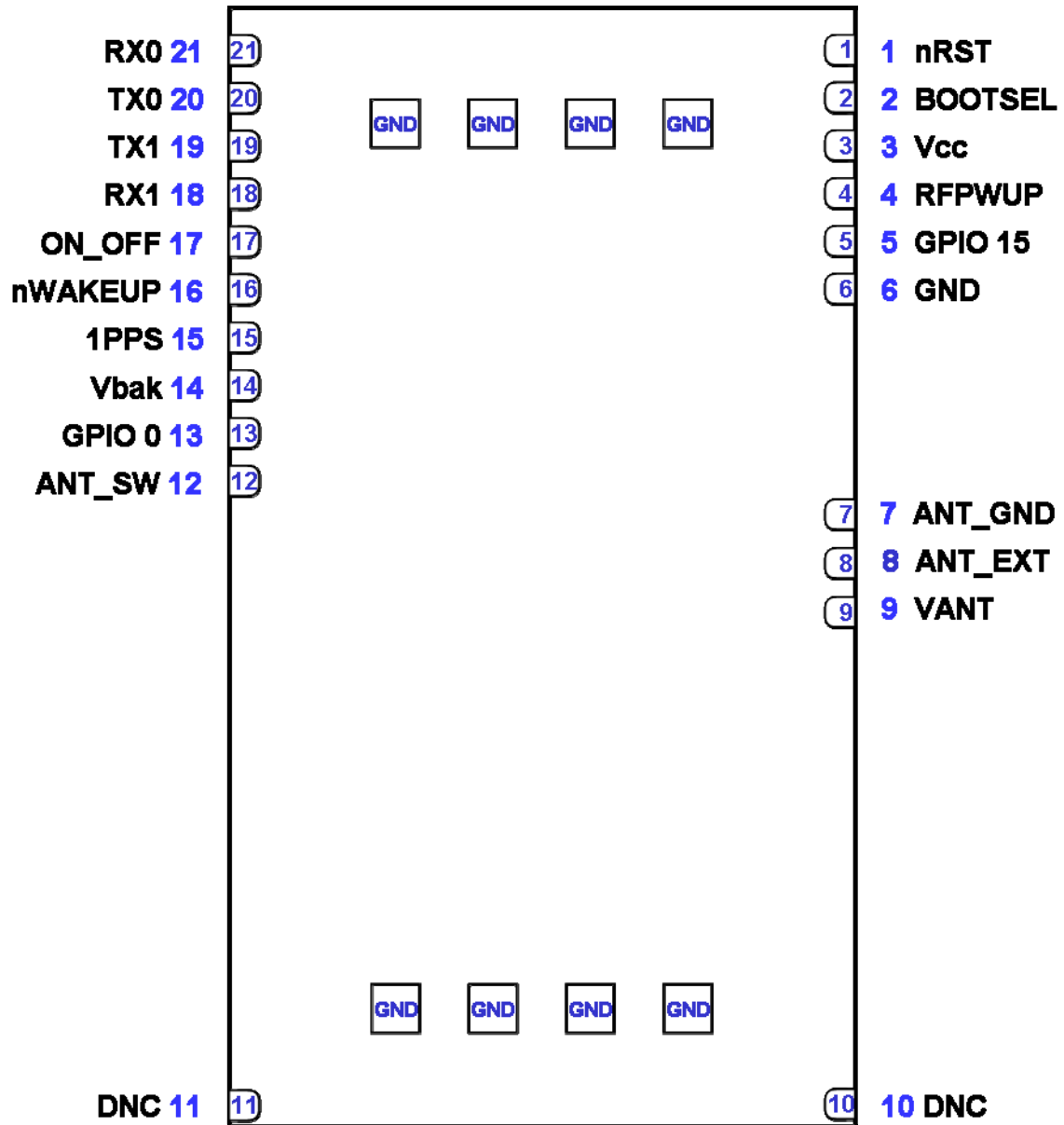

Figure 11: Pin-out information (bottom view) A1035-H

5.2 Description A1035-H Signals

Pin	Symbol	Function	Description
1	nRST	Input	Reset input (open / HIGH – no reset, LOW - reset); see “10.5 Reset Signal”
2	BOOTSEL	Input	Special boot mode – leave open for normal operation; (HIGH – boot loader active)
3	Vcc	Power Supply	3.0 – 3.6 VDC (power supply)
4	RFPWUP	Output	Status of analog section (LOW = OFF, HIGH = ON) – can be used to switch external antenna supply (see also GPIO0)
5	GPIO 15	Reserved	Reserved – leave open
6	GND	Power Supply	Ground (power supply)
7	ANT_GND	RF GND	Antenna Ground, do not connect to GROUND, connect to antenna shield
8	ANT_EXT	Antenna Input	Antenna signal / Z=50 Ohm (external active antenna input)
9	VANT	Power supply	Power supply antenna – provide according voltage (up to 5.0 VDC) - VANT feeds Pin 8 ANT_EXT
10	DNC	Do not connect to a signal	Mechanical fixture only
11	DNC	Do not connect to a signal	Mechanical fixture only
12	ANT_SW	Input	Antenna switch (LOW or open = internal antenna, HIGH = external antenna)
13	GPIO 0	Output	Antenna supply status – if LOW external antenna supply voltage can be switched off (this is not done internally!)
14	Vbak	Power Supply	Back-up pin of module for “super cap” or battery (see below)
15	1PPS	Output	1PPS (pulse per second) output
16	nWAKEUP	Output	Status of digital section (Low = ON, High = OFF) Open Drain with internal pull-up (100k), can not source current!
17	ON_OFF	Input	- ON_OFF, used in PTF mode to request a fix by toggling from LOW to HIGH - ON_OFF, used to switch to hibernate mode and back - leave open if not used
18	RX1	Input	Serial input 1 – unused in current firmware (leave open)
19	TX1	Output	Serial output 1 – unused in current firmware (leave open)
20	TX0	Output	Serial output 0, NMEA out
21	RX0	Input	Serial input 0, NMEA in

Table 5: Pin description A1035-H

5.3 General Comments

The following comments should be considered for a design with and use of the module:

- Standard configuration of serial port (standard GPS software):
Serial 0 (NMEA) 4800 baud, 8 data bits, no parity, 1 stop bit, no flow control
- External antenna (Antenna connected to Antenna Pin)
Use ground pin 7 close to the antenna input for RF ground.

6 Electrical Characteristics

6.1 Operating Conditions

Pin	Description	Min	Typical	Max
14	Vbak	1.8V		3.6V
	Standby Current ⁽⁴⁾		20µA	
3	Vcc	3.0V	3.3V	3.6V
	Peak Acquisition Current ⁽¹⁾		36mA	
	Average Acquisition Current ⁽²⁾		31mA	
	Tracking Current ⁽³⁾		26mA	

Table 6: A1035-H electrical characteristics

- (1) Peak acquisition current is characterized by millisecond bursts above average acquisition current
- (2) Average current is typically only the first two seconds of TTFF
- (3) Tracking current typically includes tracking and the post acquisition portion of TTFF
- (4) During standby state: RTC block and core powered on and clock off.

6.2 Absolute Maximum Ratings

Symbol	Parameter	Min	Max	Unit
Vcc	Power supply	-0.3	+3.6	V
Vin	Voltage to any pin	-0.3	+3.6	V
Iov	Input current on any pin	-10	10	mA
Itdv	Absolute sum of all input currents during overload condition		200	mA
Tst	Storage temperature	-55	125	°C
Vant	Antenna supply voltage	0	5.5	V
Iant	Antenna supply current	0	50	mA

Table 7: Absolute maximum ratings

Stresses beyond those listed under “Absolute Maximum Ratings” may cause permanent damage to the device. This is a stress rating only. Functional operation of the device at these or any other conditions beyond those indicated in the operational sections of this specification is not implied. Exposure to absolute maximum rating conditions for extended periods may affect device reliability.

6.3 DC Electrical Characteristics

Symbol	Parameter	Min	Max	Unit
1PPS, TX1, TX0, RFPWUP, nWAKEUP, GPIO 0	Voh	2.6	Vcc	V
	Vol		0.2	V
RX1, RX0	Vih	2.0	Vcc	V
	Vil		0.8	V
nRST	for safe reset		0.2	V
ON_OFF	Vih	0.84	1.5	V
	Vil	-0.3	0.36	V
BOOTSEL	Vih	2.3	Vcc	V
ANT_SW	Vih	2.0		V
	Vil		0.2	V

Table 8: DC electrical characteristics

7 Mounting

This chapter describes the suggested mounting process for the A1035-H receiver modules. In a RoHS compliant product with a RoHS compliant process it is recommended to use chemical tin as the counter-part to the module's pins. This will guarantee highest resistance against shocks.

7.1 Proposed Footprint for Soldering

The following proposal of a footprint for soldering is assuming a stencil thickness of 150µm. ✕ marks the center of the through holes.

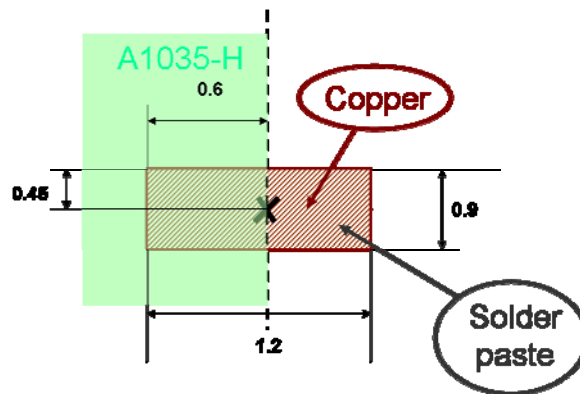

Figure 12: Soldering footprint proposal A1035-H

Please note that copper and solder paste footprint are identical. The final footprint has to be evaluated and qualified by the manufacturer according to the specific processes.

7.2 Recommended Profile for Reflow Soldering

Typical values for reflow soldering of the module in convection or IR/convection ovens are as follows (according to IPC/JEDEC J-STD-020D):

Parameter	Value
Peak temperature (RoHS compliant process)	245°C
Average ramp up rate to peak (217°C to Peak)	3°C / second max.
Preheat temperature	min=150°C; max=200°C
Ramp up time from min. to max. preheat temperature	60 ... 120 seconds
Temperature maintained above 217°C	60 ... 150 seconds
Time within 5°C of actual peak temperature	30 seconds
Ramp down rate	6°C / second max.
Time 25°C to peak temperature	8 minutes max.

Table 9: Reflow soldering profile A1035-H

As results of soldering may vary among different soldering systems and types of solder and depend on additional factors like density and types of components on board, the values above should be considered as a starting point for further optimization.

8 Use of External Antenna

8.1 Connection of RF Signal

The ANT_EXT pin is used to connect the receiver with the GPS antenna. The design of the antenna connection has to be done strictly according to RF design rules. A 50 Ω PCB strip line is required. The following drawings shall explain the guidelines. A major rule is to keep the strip line as short as possible. Additionally, antenna ground (ANT_GND) should be routed to the ground plane of the PCB (the ground plane is on a lower PCB layer) by vias as demonstrated in the drawing.

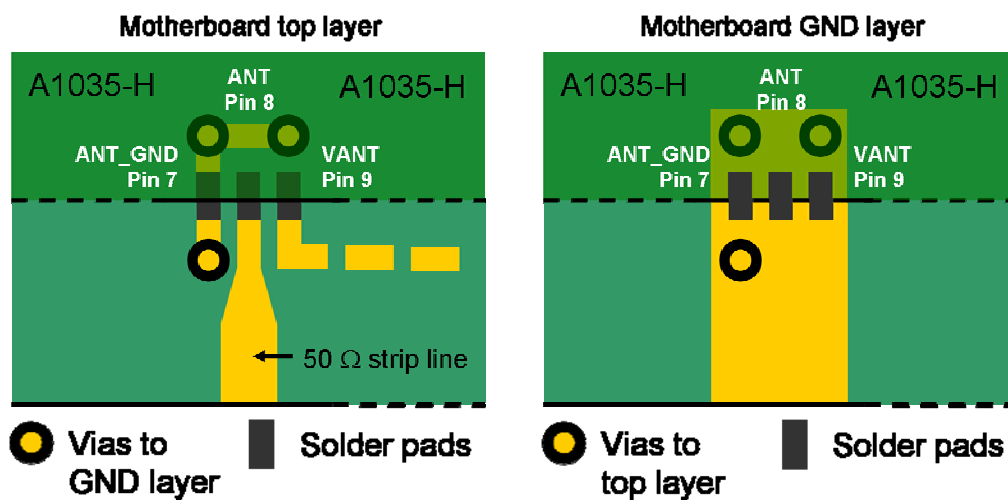

Figure 13: Antenna connector strip line A1035-H

In order to achieve the impedance of 50 Ω, the width of the strip line needs to be calculated. It depends on the thickness or height of the PCB layer (both parameters are shown in following drawing). For the calculation, it is assumed that the PCB material is FR4.

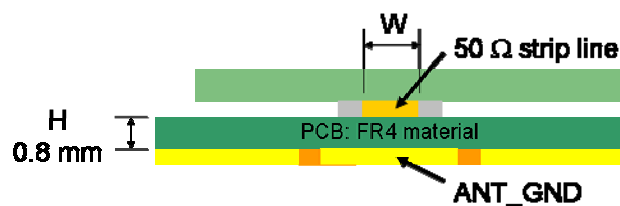

Figure 14: Strip line parameters A1035-H

In this case, the width should be about 1.8 times the height of the PCB:

$$W = 1.8 \times H$$

In the example, one would get a width of $W = 1.8 \times 0.8 \text{ mm} = 1.44 \text{ mm}$.

8.2 External Antenna

8.2.1 Recommended Parameters

General GPS active antenna specification:

Limitations:

- Supply voltage according to voltage fed into VANT pin (5 V max.)
- Supply current 50 mA (max.)

Recommendations:

- Gain ≥ 20 dB (should not exceed 35 dB)
- Noise figure ≤ 1.5 dB

The recommendations apply to the majority of active antennas that can be found in the market. The quality and suitability of the GPS antenna chosen is of paramount importance to the overall sensitivity of the GPS system.

The system design needs to reflect the supply voltage of the antenna. If the supply voltage is equal to V_{cc} , V_{cc} can be connected to VANT. If the antenna requires a different supply voltage, the antenna bias can be provided through the VANT pin.

8.2.2 Switching External Antenna Supply

This schematic is a part of the EVA1035-H (Evaluation Kit) schematics. It shows how the antenna supply voltage can be switched on and off by RFPWUP.

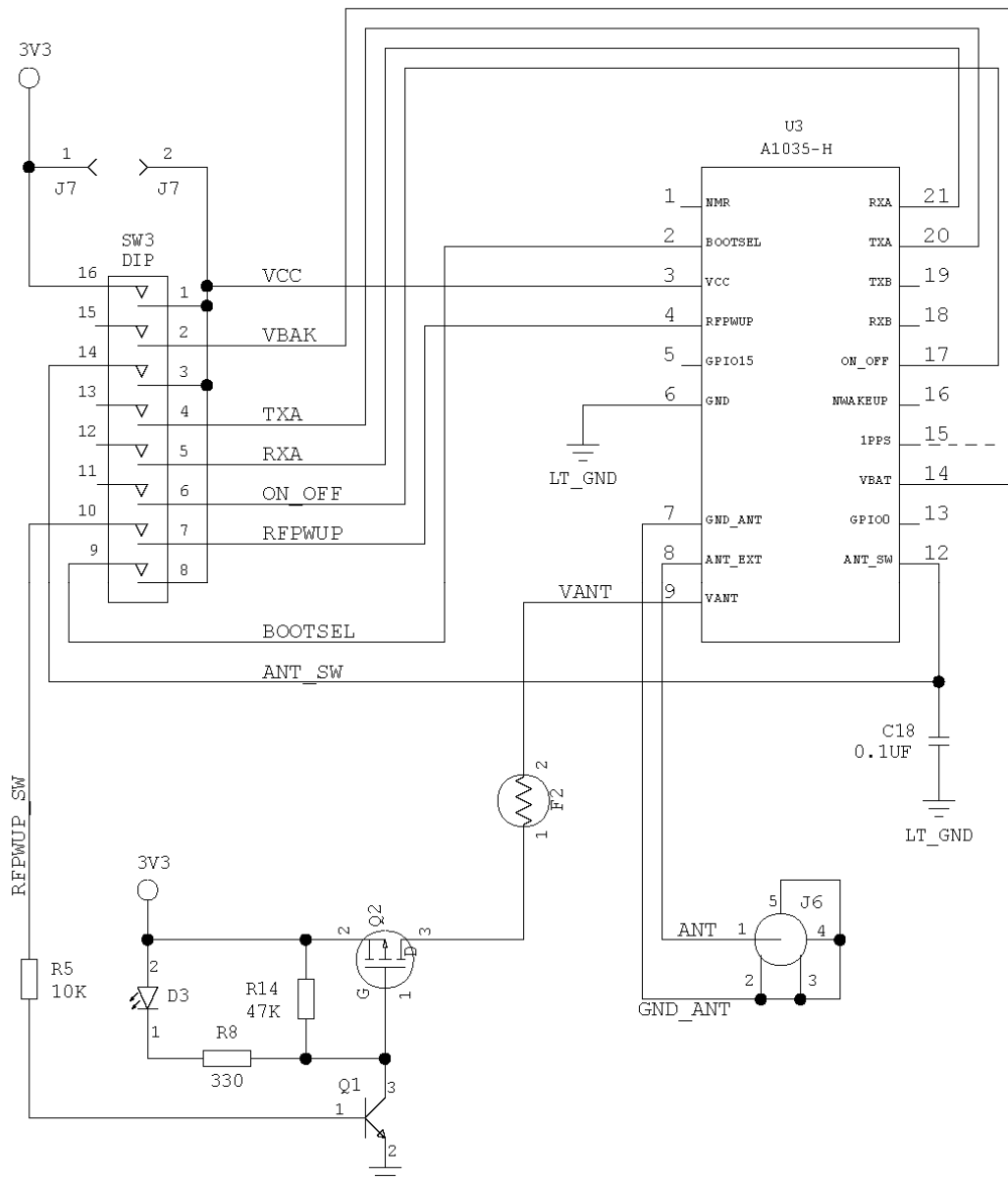

Figure 15: Switching external antenna supply using RFPWUP

8.2.3 Hints

Unused antenna inputs should be terminated with $50 \Omega \pm 20\%$. Do not feed the antenna supply voltage into terminated antenna inputs.

9 Quality and Reliability

9.1 Environmental Conditions

Operating temperature	-40°C ... +85°C
Operating humidity	Max. 85% r. H., non-condensing, at 85°C
MSL JEDEC (Moisture Sensitivity Level)	3
Storage	6 months in original package

Table 10: Environmental conditions

9.2 Product Qualification

Prior to product qualification the GPS receiver is preconditioned according to EIA/JEDEC standard JESD22-A113-B / Level 3.

Basic qualification tests:

- MSL Classification according to J-STD-020C (MSL3 @ 245°C)
- MSL Rework Compatibility according to J-STD-020C
- Temperature Cycling -40°C ... +85°C
- Temperature Humidity Bias 70°C / 85% RH
- Low / High Temperature Operating -40°C / +85°C
- High Temperature Operating Life +85°C
- Vibration Variable Frequency
- Mechanical Shock

Please contact Maestro for detailed information.

9.3 Production Test

Each module is electrically tested prior to packing and shipping to ensure state of the art GPS receiver performance and accuracy.

10 Application and Hints

10.1 Minimum Configuration

Please refer to chapter “3.1 Minimum Configuration” for details. As outlined there, for optimized start-up behavior it is strongly recommended to add a battery back-up circuit (see chapter “10.6 Battery Back-up”).

10.2 External Antenna Status Adaptation

This chapter shall give assistance in designing a circuit for detecting if an antenna is connected to the module. The information about the antenna status can be derived from the ANTSTAT signal generated by this circuit. The examples use values for components that roughly result in the following ANTSTAT output:

- Logic low when: $I_{ant} < 9\text{mA}$
- Logic high when: $9\text{mA} > I_{ant} < 16\text{mA}$
- Logic low when: $I_{ant} > 16\text{mA}$

10.2.1 External Antenna Sensor

The following circuit is a proposal on how you can feed an antenna with 3.3V and provide an output for the ANTSTAT pin. The value of the components may need an adaptation in the final application. For example, the input current of the chosen comparator goes into that equation. The thresholds defined in this circuit are quite close to the ones described above. Their value is determined by resistors R4, R5, and R3.

We strongly recommend simulating and testing the GPS receiver integrated in your product design before implementing the finalized product in the appropriate market application.

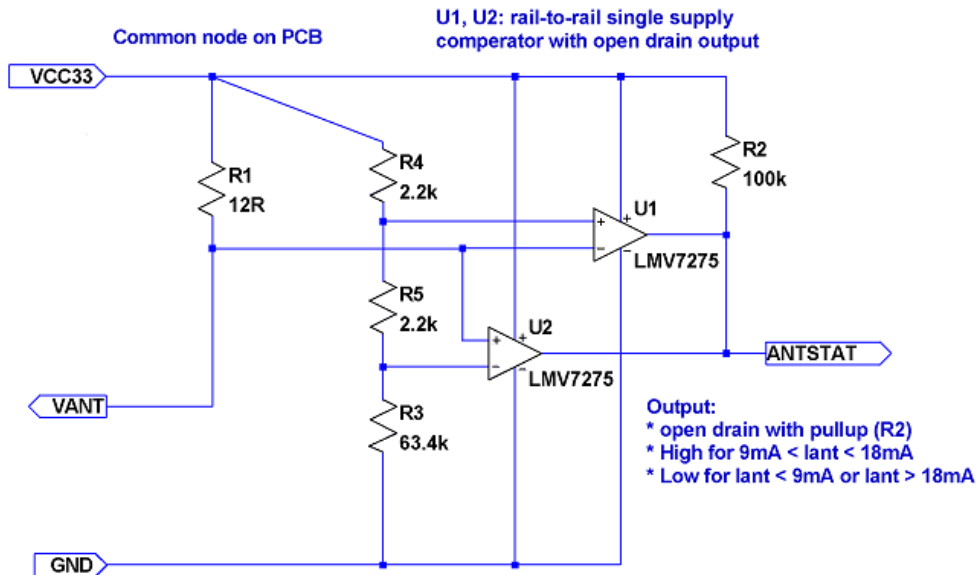

Figure 16: Application note: Antenna sensor adaptation

10.2.2 External Antenna Sensor with Current Limiter

This proposal is similar to the first one, but includes a current limiter. Comments and notes as above apply.

We strongly recommend simulating and testing the GPS receiver integrated in your product design before implementing the finalized product in the appropriate market application. In any case it is the responsibility of the designer to test and verify the implementation.

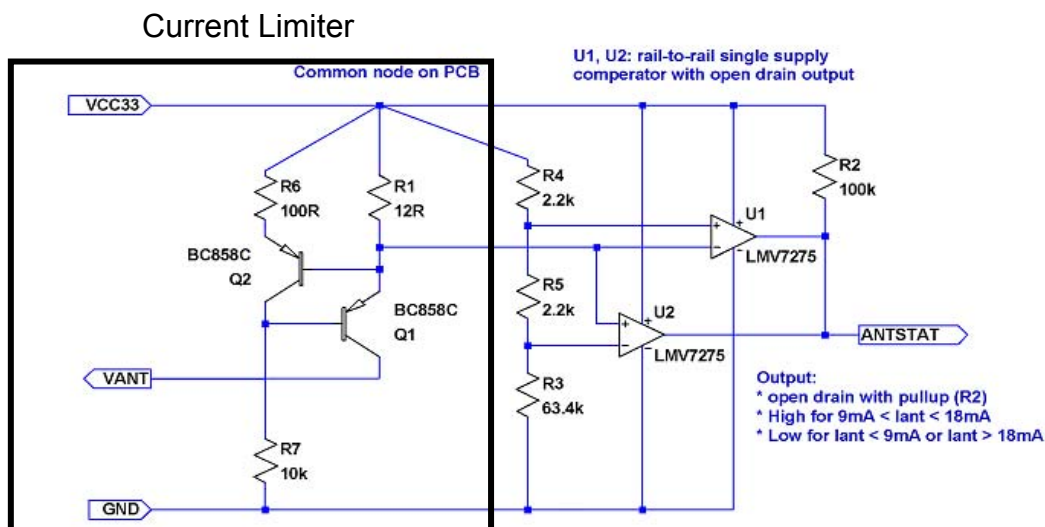

Figure 17: Application note: Antenna sensor adaptation with current limiter

10.3 VANT Pin (antenna voltage input pin)

The VANT pin is an input pin.

The supply voltage for an active GPS antenna has to be fed into the VANT pin. The easiest way to do that is to connect Vcc to VANT. The maximum current is 50 mA.

Note: Shortcut between ANT and GND may damage the A1035-H GPS receiver module. This should be avoided by using an antenna current limiter.

The circuit (chapter “10.2.2 External Antenna Sensor with Current Limiter”) works for Vcc from 3 V to 5 V. The antenna current will be limited to 50 mA approximately.

If other transistors are used, other resistor values may be necessary as well. We strongly recommend simulating and testing your completed version before using it.

10.4 1PPS Pin (1 pulse per second pin)

The 1PPS pin is an output pin.

In addition to precise positioning, GPS also allows for accurate timing due to the synchronized atomic clocks in the GPS satellites. While the current date and time is transmitted in NMEA sentences (UTC), an exact and accurate timing signal is provided via the 1PPS pin of the A1035-H GPS receiver.

Under good signal conditions the 1PPS signal comes between 620ns and 710ns after the full GPS system second which is accurately (around 10ns) synchronized to UTC. Therefore the 1 second clock can be derived and maintained within around 90ns under good signal conditions.

Note: The 1PPS clock accuracy directly depends on the position accuracy! The GPS signals travel at the speed of light, therefore a position inaccuracy directly translates into 1PPS inaccuracies.

10 m position deviation \approx 33 ns 1PPS deviation (typically)

100 m position deviation \approx 333 ns 1PPS deviation (typically)

The NMEA messages containing absolute timing information (UTC time) are provided around 300 ms after the 1PPS signal, typically. This may change according to the setup of the GPS receiver.

The 1PPS signal is provided on an “as is” basis with no accuracy specification. The given values are based on a 10 satellites, static GPS simulator scenario.

10.5 Reset Signal

The nRST pin is an input pin.

The nRST pin can be used to generate a reset on the A1035-H module. Resetting the module will result in a restart of the complete firmware. All information stored in SRAM will still be valid.

10.5.1 Internal Reset Circuit

The A1035-H is already equipped with a voltage monitoring device that generates a proper power-on reset at the appropriate threshold and delay. Additionally it addresses the brown-out protection issue. Usually there is no need to deal with the reset input externally; therefore, the general advice is to leave this pin open.

10.5.2 External Reset Circuit

If, for some reason(s), an external reset input is really desired, the following instructions are recommended:

Only use an open drain/collector device (e.g. a bipolar NPN transistor to ground, see below) to pull the nRST pin low in order to issue a reset.

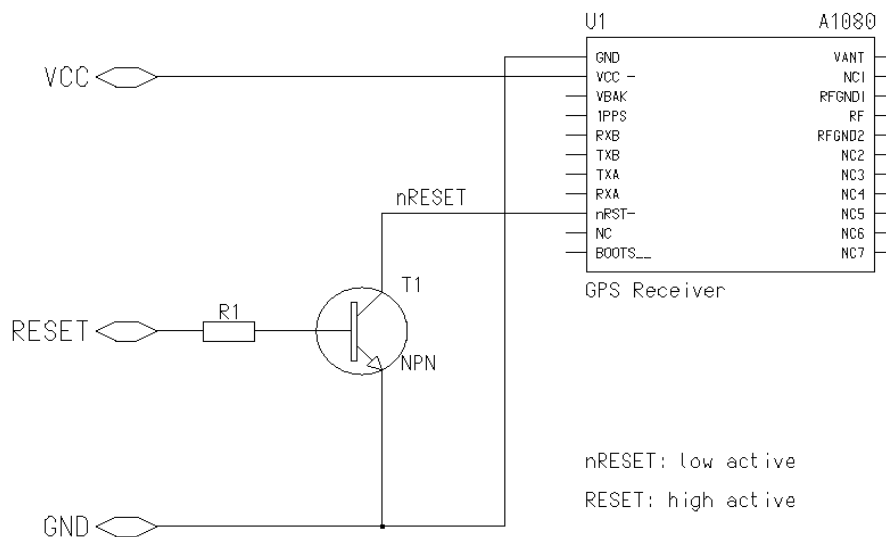
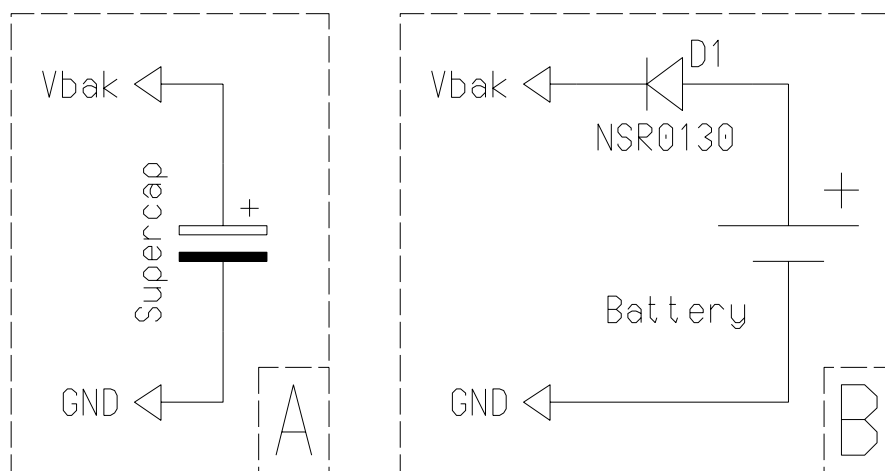

Figure 18: Application note: Recommended external reset circuit

10.6 Battery Back-up

This application note describes how to back-up the RTC and the SRAM of the GPS receiver module. The basics of the first example addresses providing a back-up power supply by using a separate battery or a “Supercap”.

While the “Supercap” is charged through the module during normal operation, the battery (primary cell) is decoupled thru a diode!



Backup Supply Options
 (A) Supercap, charged through GPS module
 (B) Primary cell, decoupled with diode

Figure 19: Application note: Module back-up

An alternative to this solution is to switch the supply voltage from the Vcc pin to the Vbat pin. Care needs to be taken that there is no voltage outage during the switch-over phase!

The Vbak pin draws 20 μ A typically.

10.7 Push-to-Fix Mode

Push-to-Fix mode is designed for the application that requires infrequent position reporting. The receiver generally stays in a low-power mode, up to 2 hours, but wakes up periodically to refresh position, time, ephemeris data and RTC calibration.

The push-to-fix mode is initialized and entered using the SiRF Binary Protocol. Please refer to the appropriate manual, paying particular attention to the paragraph titled “Set TricklePower Parameters”. In order to request a fix outside the specified duty cycles, it is necessary to toggle the pin ON_OFF. Toggling is done by pulling the signal to HIGH for about 100ms.

For more information see “GPS AppNote Firmware GSC3”.

10.8 Hibernate Mode

The two ways as described within this paragraph to send a module into Hibernate Mode should be implemented in order to avoid loss of data which might in rare cases lead to a cold start of the module.

10.8.1 Entering Hibernate Mode with ON_OFF Pin

From firmware version 3.2.5, firmware support for ON_OFF has been included, hence, a rising pulse on the ON_OFF pin will put the A1084 GPS receiver into hibernate state if it is on and wake it up if it is in sleep state. During sleep state the receiver draws 20 μ A typically and maintains RTC and SRAM. Here Vcc must not be switched off. See also “Figure 5: Minimum configuration A1035-H with continued Vcc supply”. Therefore this method can be used for configurations where no additional Vbak is available.

10.8.2 Entering Hibernate Mode with Shutdown Command

When a separate Vbak supply is foreseen, an alternative method to enter Hibernate Mode is by sending a shutdown command. From firmware version 3.5.0 onwards this is possible using the command

```
$PSRF117,16*0B
```

In NMEA mode as described in the manual “GPS Firmware GSC3 3.5.0”. In SiRF Binary mode the according command can be found in the “SiRF Binary Reference Manual” – Software Commanded Off – Message ID 205. After a delay of about 2 s or after the signal RFPWUP went LOW Vcc can be disconnected. The RTC will keep on running and SRAM is backed with the typical current of 20 μ A drawn from Vbak. See also “Figure 6: Minimum configuration A1035-H with Vbak”.

11 Evaluation Kit EVA1035-H

For demonstration and easy evaluation of GPS performance Maestro offers an evaluation kit (including one GPS A1035-H module). It contains a USB interface with according drivers to connect easily to a PC. The USB interface is an extension of the serial port 0, therefore sending NMEA sentences and accepting commands. At the same time it provides power to the module. Accompanied by an antenna it offers a ready-to-go set.

For the development of new software and applications the Evaluation Kit also provides NMEA messages on CMOS level via a terminal plug.

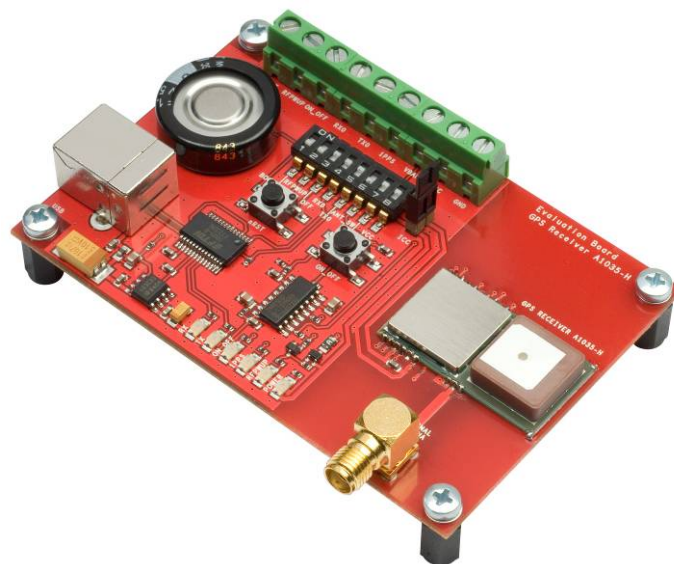

Figure 20: Evaluation kit EVA1035-H

For further information please contact Maestro.

12 Related Information

12.1 Contact

This manual was created with due diligence. We hope that it will be helpful to the user to get the most out of the GPS module.

Any inputs regarding possible errors or mistakable verbalizations, and comments or proposals for further improvements to this document, made to Maestro, Hongkong, are highly appreciated.

Maestro Wireless Solutions Limited

Add:Unit 3603-09,36/F.,118 connuaught Road West,HK

Main Line: (852) 28690688

Fax: (852)25254701

support-gps@maestro-wireless.com

www.maestro-wireless.com

12.2 Related Documents

- GPS Firmware GSC3 (Maestro)
- GPS Evaluation Kit EVA1035-H (Maestro)
- SiRF_Binary_Reference_Manual (SiRF)
- SiRF_NMEA_Reference_Manual (SiRF)
- GPS AppNote Firmware GSC3 (Maestro)
- GPS AppNote Ephemeris Push GSC3 (Maestro)
- GPS AppNote Backup GSC3 (Maestro)
- GPS AppNote EDLC-Backup GSC3 (Maestro)
- GPS AppNote 1PPS Pulse Width GSC3 (Maestro)

12.3 Related Tools

- GPS Cockpit (Maestro)
- SiRF Demo (SiRF)
- SiRF Flash (SiRF)

13 List of Figures

Figure 1: A1035-H label	6
Figure 2: A1035-H tape specifications (1)	8
Figure 3: A1035-H tape specifications (2)	9
Figure 4: A1035-H tape specifications (3)	9
Figure 5: Minimum configuration A1035-H with continued Vcc supply	12
Figure 6: Minimum configuration A1035-H with Vbak	13
Figure 7: RS232 level shifter for minimum configurations	14
Figure 8: BOOTSEL application	15
Figure 9: Mechanical outline component side A1035-H	16
Figure 10: Mechanical outline solder side A1035-H	17
Figure 11: Pin-out information (bottom view) A1035-H	18
Figure 12: Soldering footprint proposal A1035-H	23
Figure 13: Antenna connector strip line A1035-H	25
Figure 14: Strip line parameters A1035-H	25
Figure 15: Switching external antenna supply using RFPWUP	27
Figure 16: Application note: Antenna sensor adaptation	30
Figure 17: Application note: Antenna sensor adaptation with current limiter	30
Figure 18: Application note: Recommended external reset circuit	32
Figure 19: Application note: Module back-up	33
Figure 20: Evaluation kit EVA1035-H	35

14 List of Tables

Table 1: A1035-H GPS characteristics.....	7
Table 2: A1035-H dimensions and weight.....	7
Table 3: Additional equipment.....	11
Table 4: BOOTSEL Operating mode	15
Table 5: Pin description A1035-H	19
Table 6: A1035-H electrical characteristics	21
Table 7: Absolute maximum ratings.....	21
Table 8: DC electrical characteristics	22
Table 9: Reflow soldering profile A1035-H.....	23
Table 10: Environmental conditions	28